

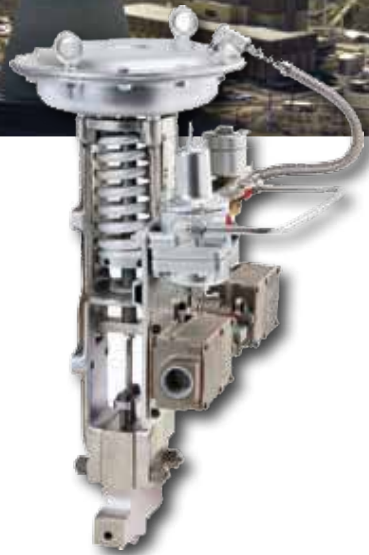

COPES-VULCAN
AN SPX BRAND

Containment Sampling Isolation Valve

Model F100-40 For Nuclear Applications



SPX[®]

Features

The Copes-Vulcan Model F100-40 valve can solve your leakage problems in critical applications by offering:

- Positive shutoff
- Reliable operation
- Radiation resistant materials
- Fast, easy maintenance
- No need for piping supports or restraints

3/8" (10mm) Sampling Valve

The Copes-Vulcan F100-40 Sampling Valve was developed to provide positive shutoff and reliable operation for both sampling and containment isolation applications in nuclear power plants.

Such high-pressure water, steam and gas applications demand exceptional seat tightness. The Copes-Vulcan design incorporates a high-thrust actuator with thru-hardened trim components to ensure better than ANSI 70-2 Class V leakage at 2500 psid (17,225 kPa).

The valve was designed, built and tested in accordance with ASME Boiler and Pressure Vessel Code Section III for Classes 1, 2 or 3. ANSI B16.34 valves are also available. A maximum design pressure and temperature rating of 2500 psig (17,225 kPag) at 680°F (360°C) is standard.

Materials of construction were chosen for borate water service. These same materials are excellent choices for service water, steam and hydrogen media. Stainless steel is used for body, seat, plug/stem, actuator frame, frame-to-body mounting components and packing gland. The absence of hardfacing limits cobalt to minor residual elements.

The use of inert and radiation-resistant materials reduces maintenance and the risk of failure. The only non-metallic component used on the valve assembly that could experience degradation from exposure to radiation is the diaphragm. Copes-Vulcan has qualified the EPDM diaphragm material to 20 years service at 2.0×10^7 rads.

Piping supports and restraints are eliminated by the convenient actuator wall-mounting of the entire valve. This design allows groups of valves to be bank or gang-mounted.

Maintenance time and costs are also greatly reduced by the trim and packing gland arrangements. While the actuator may be removed from the valve when necessary, there is no need to do so when repacking or changing the trim. Ease of trim removal and a minimum of components involved (plug/stem, seat, packing and two seals) allow maintenance personnel to get the job done fast, which is especially important during short outages or when working in hot areas of the plant. Packing life is extended by backseat, double-packed stuffing box and leak-off features.

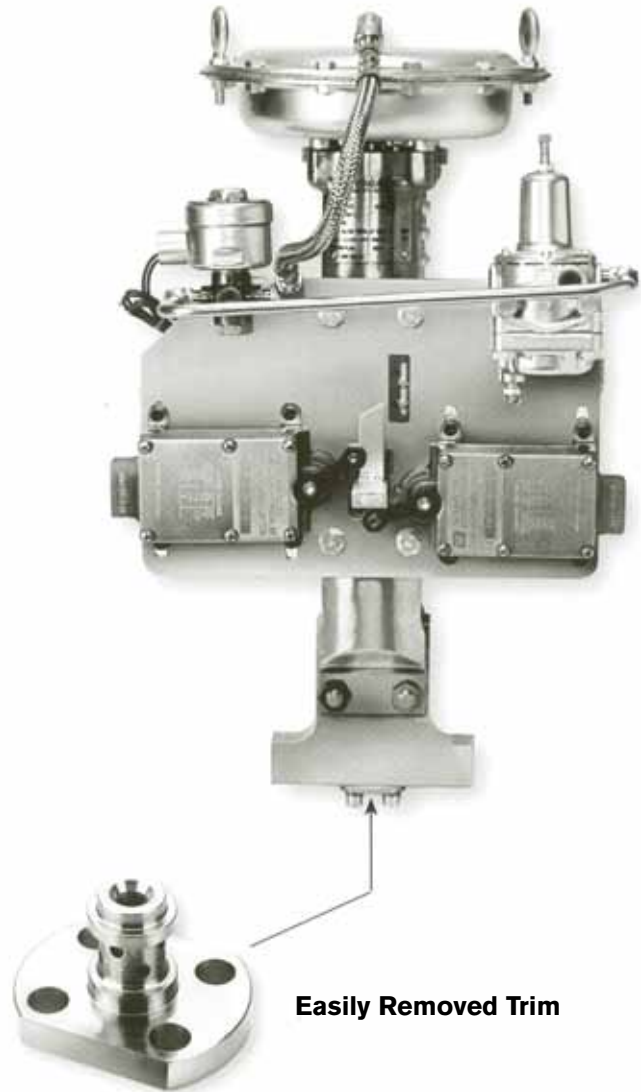

Easily Removed Trim

Design Evaluation Testing

Over 45,000 hot cycles and this containment sampling/isolation valve still exceeds leakage requirements.

Purpose

The testing at our Lake City, Pennsylvania plant was designed to evaluate the performance of the Copes-Vulcan 3/8" (10mm) Sampling/Isolation Valve while operating under expected service conditions as simulated by the Copes-Vulcan hot test loop.

Description

The valve was cycle tested in a pressurized water hot flow loop.

Conclusion

The valve performed successfully in all phases of operation, including 45,500 hot cycles with no loss of structural integrity.

Preliminary Testing

A baseline of satisfactory operation was established during preliminary testing at ambient temperature:

Fluid Boundary Integrity

Hydrostatic testing at 5825 psig (40,135 kPag).

Mainseat Leakage

Zero leakage obtained at 2500 psi differential (17225 kPa differential), thus exceeding the requirements of FCI 70-2/ANSI Class V.

Cycling

100 cycles with 2500 psi differential (17,225 kPa differential) closed and 500 psi differential (3445 kPa differential), minimum, open.

Stroke times:

Closing — .4 seconds

Opening — .4 seconds

Hot Testing

A testing model was configured with 630°F (332°C) water at 2500 psig (17,225 kPag).

Hot Cycles

45,500 cycles were successfully performed. 26,800 hot cycles were conducted with 2500 psi differential (17,225 kPa differential) in closed position, and a minimum of 500 psi differential (3445 kPa differential) in open position. The remainder of the cycles were conducted at system pressure. Stroke times of .4 second closed and .4 second open were typical throughout.

Hot Mainseat Leakage

The mainseat leakage was measured frequently during cycling (every 1000 cycles minimum) and exceeded the FCI 70-2/ANSI Class V requirements throughout.

Specifications

Materials

Body	ASME-SA182, Grade F316
Seat	ASME-SA479, Type 410
Plug/Stem	ASTM-A276, Type 420
Frame	ASTM-A351, Grade CF8M

Features

End Connections	Socket weld to accept 3/8" (10mm) O.D. tubing
ANSI Pressure Class	Special Intermediate Class 1550
Actuator	Fail closed or fail open
Seating Thrust	960 lb (4270 N) fail closed
	1600 lb (3230 N) fail open
Accessories	Filter Regulator
Seismic Qualification	2g vertical, 3g horizontal

Options

Leak-off	1/4" (8mm) tapped and plug
Accessories	(2) limit switches and solenoid (IEEE-qualified where required)
End Extensions	3/8" (10mm) stainless steel tubing factory-welded to meet existing end-to-end connections and allow instant installation between compression fitting, 3/4" (20mm) socket adaptors, etc.

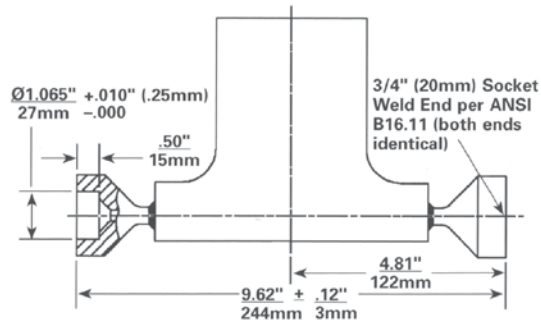
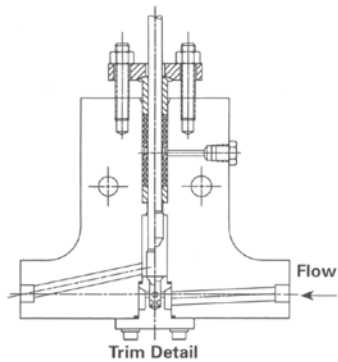
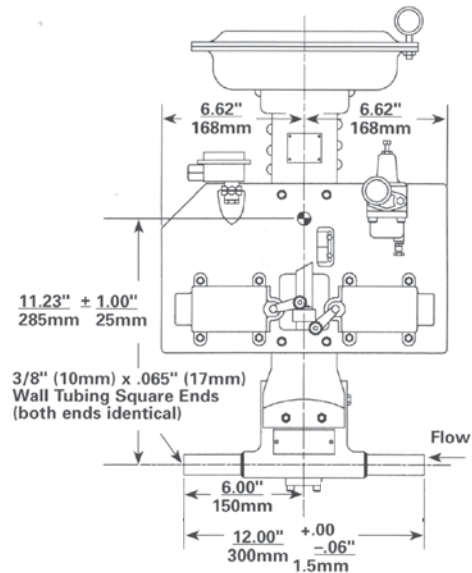
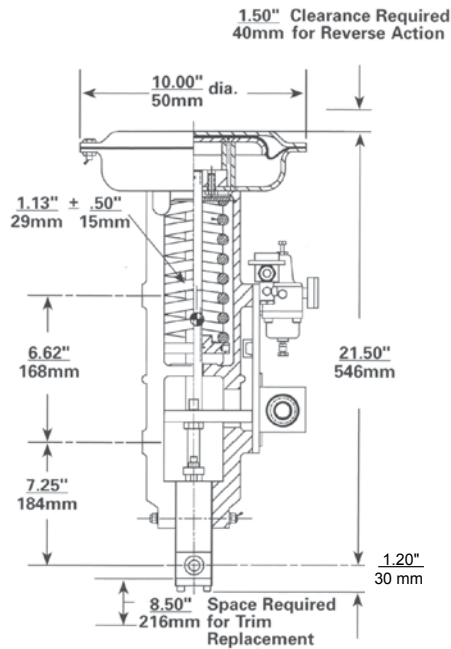

SPX®

Your local contact:



Copes-Vulcan, An SPX Brand

5620 West Rd.

McKean, PA 16426

Phone: (814)476-5800 Fax: (814)476-5854

E-mail: cv@spx.com

www.copesvulcan.com

www.spxft.com

For more information about our worldwide locations, approvals, certifications, and local representatives, please visit www.spxft.com.

SPX Corporation reserves the right to incorporate our latest design and material changes without notice or obligation.

Design features, materials of construction and dimensional data, as described in this bulletin, are provided for your information only and should not be relied upon unless confirmed in writing.